

**T2006OPT**  
**T523OPT**  
**T522OPT·SNC**  
**T521OPT·SNC**

•••  
AUTOMATIC PROGRAMMABLE CUT-OFF SAW

*WOOD be nice.*

OMGA



# T2006 OPT

AUTOMATIC CUT OFF SAW FOR DEFECTING AND OPTIMIZED CUTTING.

Feeding by pusher available in 4 or 6 meters useful length. The pusher carriage, complete with a camera for detecting chalk marks identifying the defects and a sensor for the length of the board, lifts up pneumatically in order to completely scan the board during its way back to loading position and allow a total optimization managing up to 3 different

grades. A vertical pneumatic gripper allows strict tolerances on the cut lengths  $\pm 0,15$  mm, even at maximum speed of 240 m/min. The control, with operating system Windows 7, is complete and user friendly. Two clamps on the sides of the saw blade ensure the correct positioning of the material against the fence both during the feeding and during the cutting cycle. On request the cutting line can be completed with a width scanner, an ink-jet printer and with various length sorting systems.

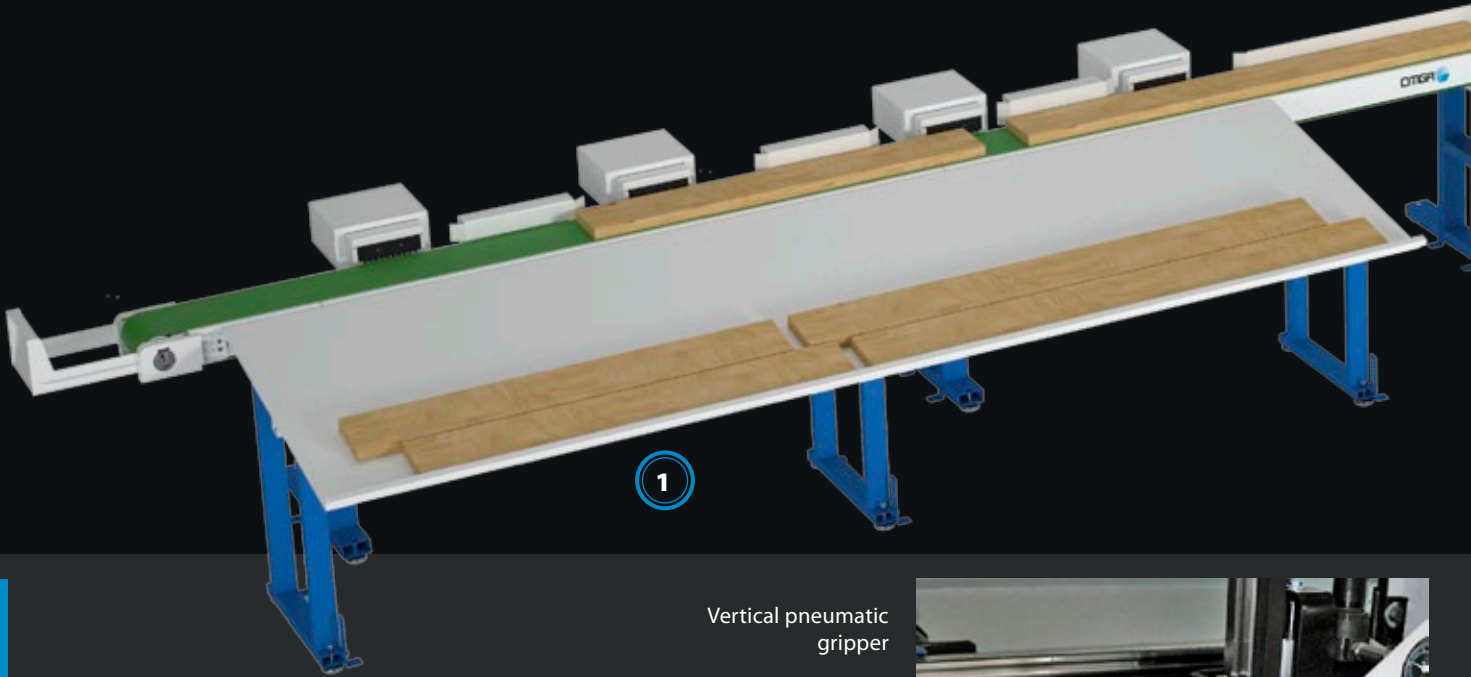

Vertical pneumatic gripper

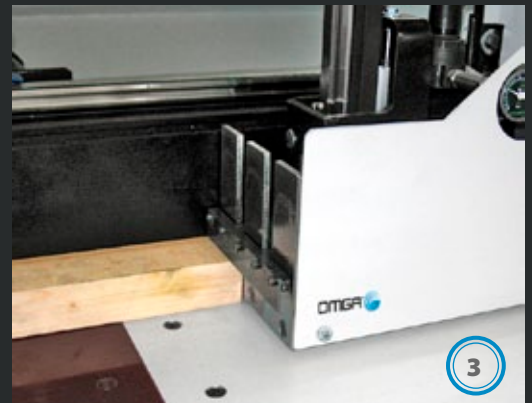

Sensor for width scanning of material

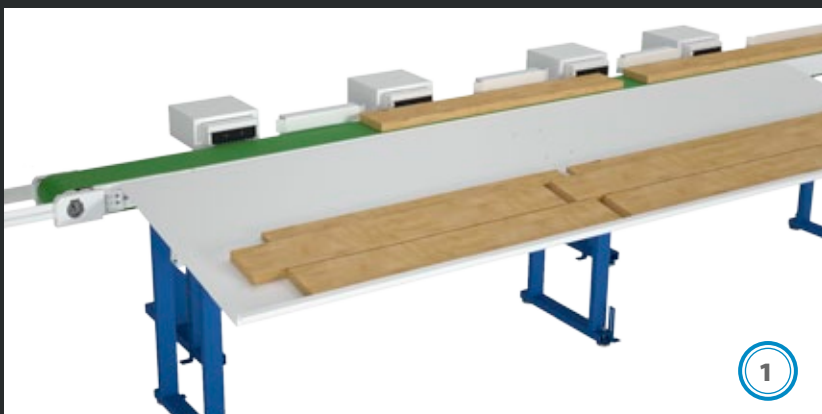

Single side sorting unit.



Ink-jet printer on top face.



Fixed clamps.

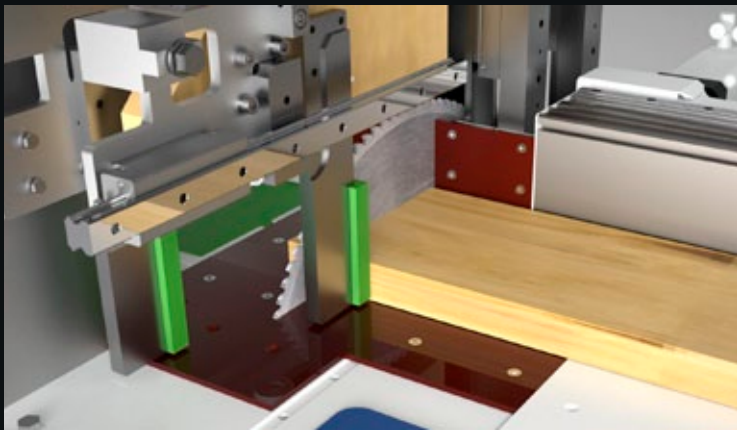

Cut with preset sequence.

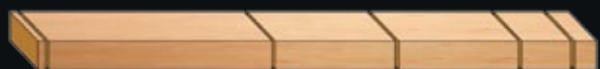

Cut with total optimization with 6 different criteria.



Defecting plus optimizing.



Defecting with trim cut on the two sides.



Waste recovery for finger jointing (•).



Waste splitting (X).

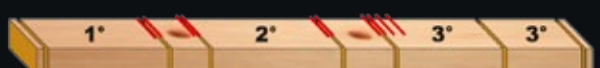

Cutting lists on three grades by marking on same faces.

# T523 OPT

PUSH-FEED OPTIMIZER FOR THE DEFECTING AND FULL OPTIMIZATION OF WOODEN PIECES.

A pneumatic tail clamp system ensures the accurate handling of the boards, during the positioning in between each cut. Two horizontal clamps self-adjust based on the cross section of the work piece and, ensure that the board is square against the fence, before each cut.

The marking of the defects is done through a fluorescent crayon.

The phase of reading the defect marks and length of the board occurs automatically, during the return stroke of the pusher.

The NC controller associated with the industrial 10.4" touch screen display, allows for easy data entry as well as an intuitive mean to access all the optimization programs. A USB port as well as an Ethernet RJ45 port allow the connection to company networks.

The statistical data on the program being executed, are always available to view by the operator, without interrupting the cycle of the machine.

The T 523 OPT is capable of handling three different grades of material, simultaneously.

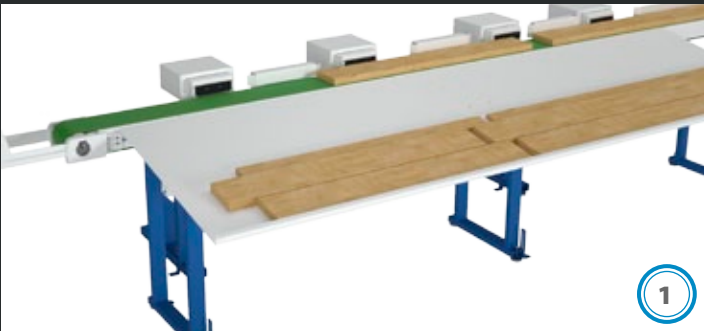
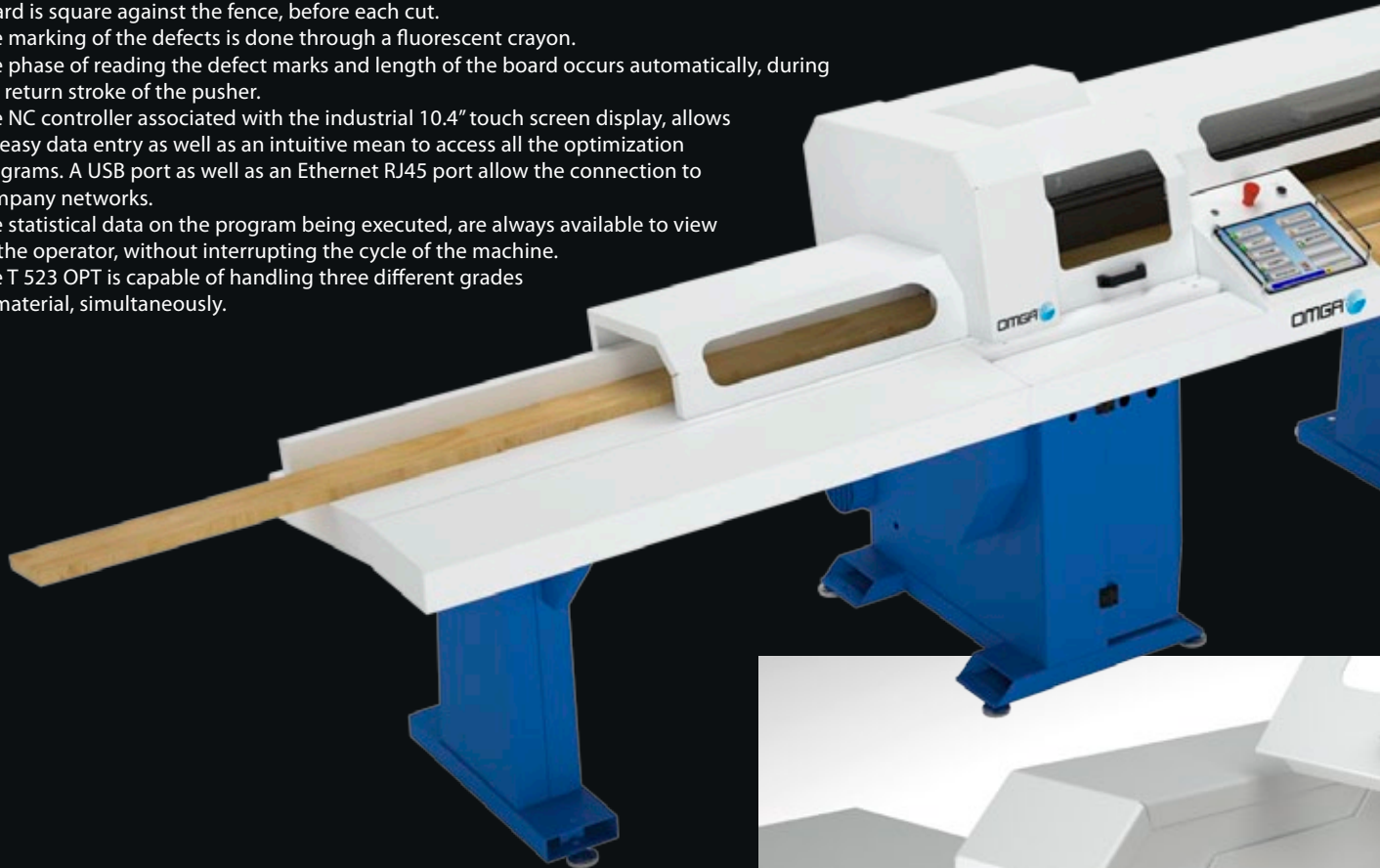

Single side sorting unit.



Ink-jet printer on top face.



Vertical pneumatic gripper

OPTIONAL



The cutting line may be completed with a variety of optional equipment, such as:

- Ink-Jet printer
- Label Printer
- Automatic piece sorting and unloading system



Defecting cut.



Cut with preset sequence.



Defecting plus optimizing.

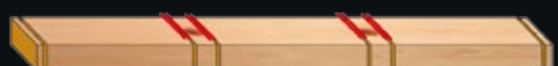

Defecting with trim cut on the two sides.



Cutting list on two grades.

# T522OPT·SNC

# T521OPT·SNC

1

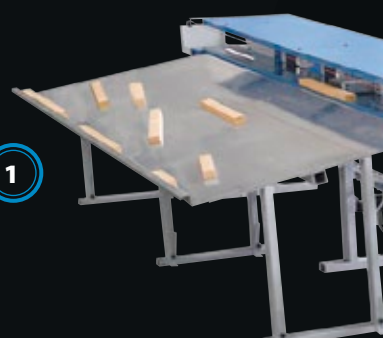

**SNC** simple and easy to use, perfect for cut to length and a first step towards optimising. The SNC version is extremely simple to use as you can work both choosing the longest measure among the cutting list and with preset sequences once optimisation has been calculated in advance by the operator.

**OPT** capable to perform full optimising as well as defecting. The software of the OPT version allows full optimising of the board handing up to two different grades. The reading of the board is performed through a laser beam with maximum precision as well as perfect quality. The operator can easily inspect the four sides of the board. The control unit is completed by a graphic screen for a continuous check of the cutting list, as well as of the status of the cutting process. The graphic display also allows the inspection of the marked board before starting the cutting operation.



T521SNC

OPTIONAL T522 - T521



1

Single side sorting unit.



2

Ink-jet printer on top face.



3

Precision measurement by magnetic tape.

2

4

**T5220PT**



4

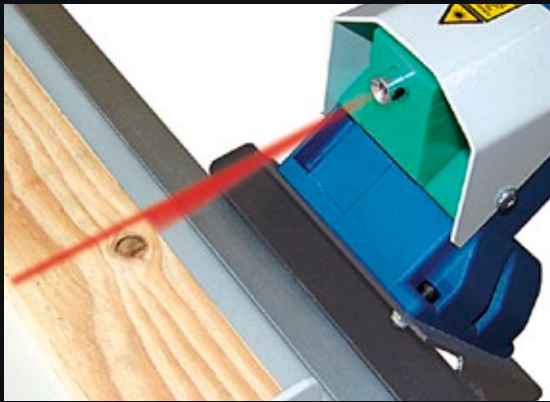
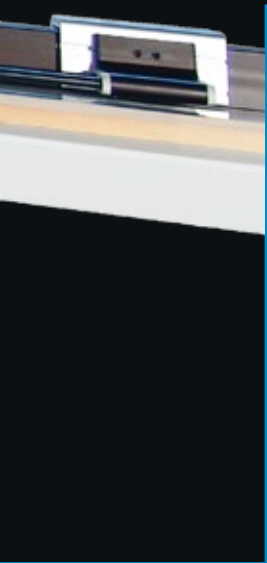

Laser Marker

Vertical pneumatic gripper

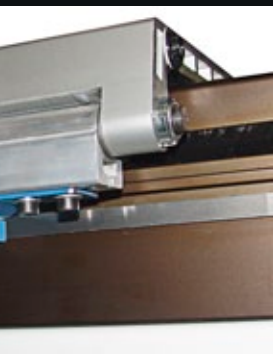

4

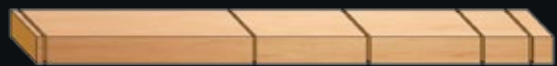

Cut with preset sequence.



Optimized cutting.

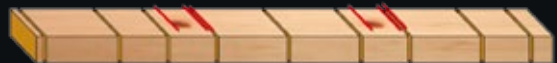

Defecting plus optimizing.



Defecting with trim cut on the two sides.

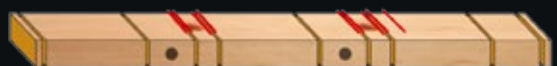

Cutting list on two grades.

		T2006	T523	T522	T521
	mm (L x H)	215 x 100 244 x 80 275 x 50 300 x 18	180 x 110 (X)  240 x 80(Y)	200 x 110 245 x 80 275 x 50 300 x 14	200 x 110 245 x 80 275 x 50 300 x 14
	standard Ø 450				
	mm (L x H)	220 x 120 240 x 110 280 x 80 300 x 50		200 x 140 250 x 110 280 x 80 300 x 50	200 x 140 250 x 110 280 x 80 300 x 50
	optional Ø 500				
	mm	A = Ø 450 B = Ø 35	A = Ø 450 B = Ø 35	A = Ø 450 B = Ø 35	A = Ø 450 B = Ø 35
	RPM	3000 n/1' opt. Ø 500	3000 n/1' opt. Ø 500	3000 n/1' opt. Ø 500	3000 n/1' opt. Ø 500
	kW	1 x 5,5 kW 1 x 2,0 kW	1 x 4,6 kW 1 x 400 W	1 x 4,6 kW 1 x 400 W	1 x 4,6 kW 1 x 400 W
	Ø mm	200	160	160	160
	L x W x H mm	6000x925x1432 (4000) 8000x925x1200 (6000)	6040x1100x1410 (4200) 8040x1100x1410 (6200)	6365x925x1410 (4000) 8045x925x1410 (6000)	6365x925x1410 (4000) 8045x925x1410 (6000)

### "Typical" line

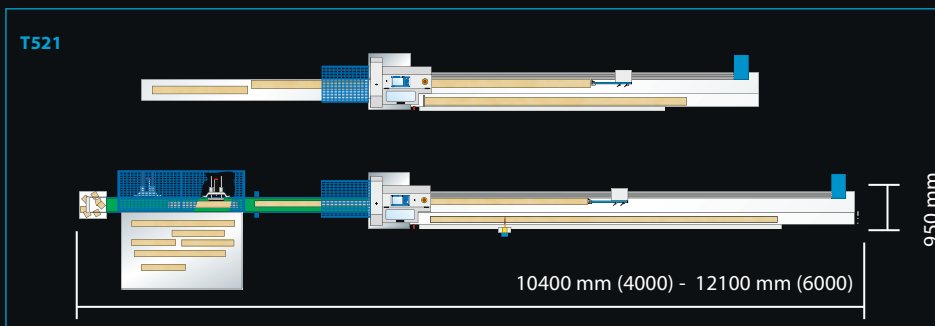
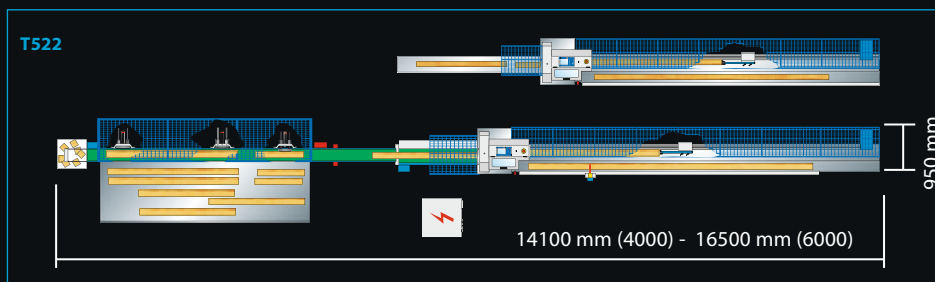
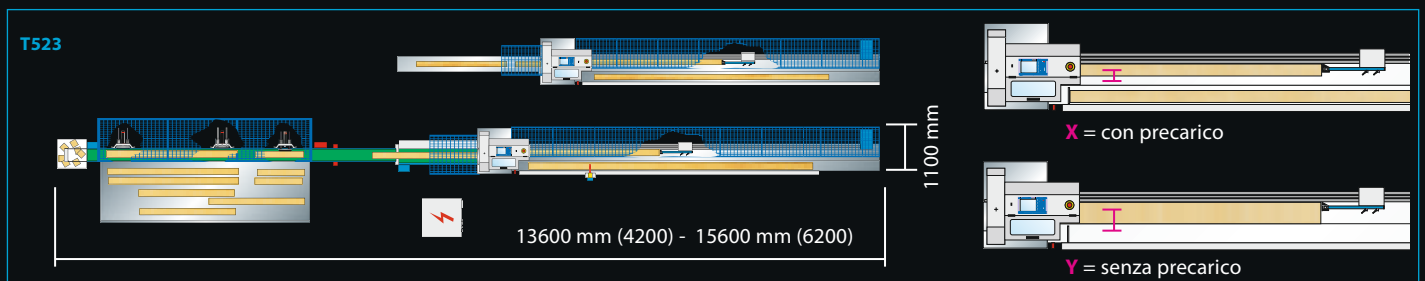
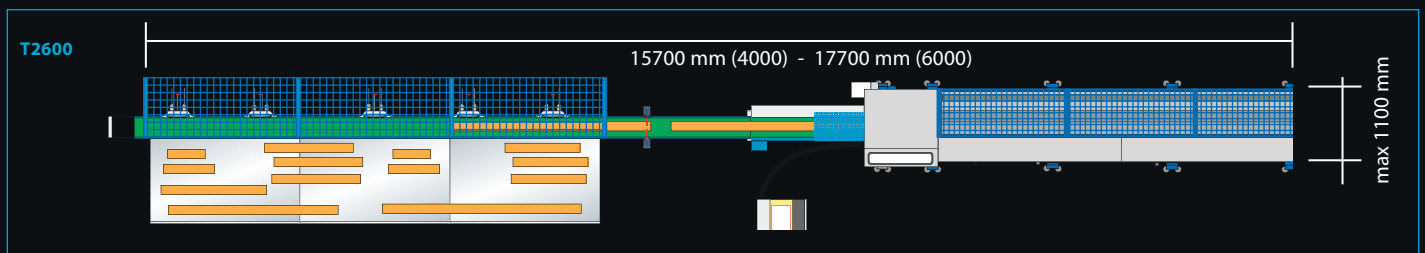

2900204534.01

### OMGA, Inc.

3705 William Richardson Drive  
South Bend, IN 46628  
USA  
Tel.: +1 (574) 243-0120  
Fax: +1 (574) 243-0216  
Toll Free: 1-800-233-OMGA (6642)  
E-mail: info@omgainc.com

[WWW.OMGAINC.COM](http://WWW.OMGAINC.COM)

